

# SDX<sup>®</sup>V Spray Dry Nozzle

Product Guide



**Our SDX<sup>®</sup>V  
is designed to  
be user-friendly  
while delivering  
superior spray  
drying performance.**

*Bob McCarthy*  
Engineering Manager

Precision Tested.  
People Trusted.

**DELAVAN<sup>®</sup>**  
SPRAY TECHNOLOGIES





We deliver  
nozzles  
you can  
depend on.

**Delavan® Spray Technologies Continually Meet Your Manufacturing Challenges.**

Delavan® Spray Technologies, part of The R.W. Beckett Corporation, is a world leader in the design and manufacture of high quality spray nozzles and fluid handling systems. Since the company was founded back in 1935, the Delavan® name has always stood for quality, flexibility, and reliability.

**We Invest in Quality and Performance.**

The substantial investment that Delavan® has made in the last few years in state-of-the-art machining centers has improved quality and lead time reduction. Combined with our high-tech laser marking and premium quality packaging, this ensures that all genuine Delavan SDX® components reach customers in

a timely fashion and in pristine condition. Delavan® remains committed to providing all customers with the reliable delivery of premium quality products, which offer the kind of performance and benefits expected from the nozzle technology leader.



# Our nozzles come with technical expertise & training.

## We Call it the *Delavan® Difference.* And Here's Why:

### **Versatility**

13 swirl chamber sizes with orifice discs from 0.4mm (0.016") - 6.4mm (0.252"). The large number of swirl chamber and orifice sizes provide customers with more options and can be paired in a variety of combinations to create the droplet size, flow rate, spray angle and exact product quality.

### **Customization**

Custom spray characteristics to meet a variety of application needs; such as droplet and particle size, spray angle, flow variation and liquid properties.

### **Durability and Wear Resistance**

Our nozzles are available in materials that will resist chemical attack such as sintered carbides and various grades of stainless steel.

### **Technical Expertise**

Almost every dryer requires a unique solution depending on feed material, capacity, and operating conditions. Delavan® understands the issues inherent in spray drying and will recommend the right nozzle for the best possible performance.

## **Nozzle Characteristics**

- Wear parts positively retained during assembly, eliminating the possibility of component breakage and minimizing the risk for misalignment during assembly.
- Patented orifice design with a proven increase in wear life over standard flat orifice discs.
- Hand tight design for ease of assembly and reduced maintenance.
- Metal to metal secondary sealing of the nozzle body and adaptor.
- Swirl chamber and retainer variations to suit customer specific requirements.
- Female threaded adaptors minimizing the risk of thread damage during routine lance change outs.
- Widest range of orifice disc and swirl chambers on the market.
- Multiple grades of carbide to minimize wear life.

# SDX<sup>®</sup> V Nozzle

## Better Wear Resistance and Ease of Maintenance.

The SDX<sup>®</sup> V nozzle features an 8 part construction and is the world's most user-friendly spray drying nozzle, requiring only hand tight engagement of the nozzle body into the adaptor throughout the pressure range.

Additionally, the SDX<sup>®</sup> V features an alternative design of swirl chamber that allows for improved wear life and effortless maintenance for the lowest cost of ownership. In this design, the end plate is no longer integrated but is supplied as a separate component.

In certain circumstances, cavitation or abrasive particles cause increased wear on the bottom of the standard chamber, which wears out before the walls or the inlet throat. The separate end plate can then be replaced and the 'open' swirl chamber reused, significantly reducing the cost of ownership. There is also the option to use end plates with improved wear characteristics or chemical resistance.

The new swirl chamber required the introduction of a revised retainer designed to centralize the end plate onto the chamber and lock all components into place. It also has a lower pressure drop and improved blockage resistance compared to the existing retainers.



**Option 1**  
The original swirl chamber design is the standard for SDX<sup>®</sup> V nozzles.



**Option 3**  
The open swirl chamber is ideal for highly abrasive applications since the end plate can be replaced completely independently of the swirl chamber.



**Option 2**  
The Flat Back version can be used where materials with a high solids percentage are to be atomized.

# SDX® V Nozzle

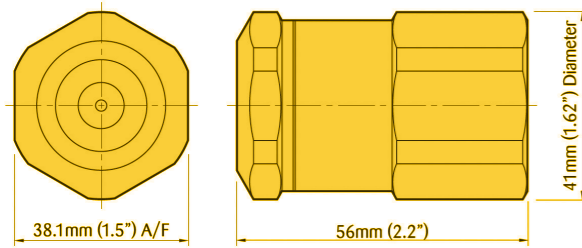

The SDX® V features an 8 part construction and is the world's most user friendly spray drying nozzle, requiring only hand tight engagement of the nozzle body into the adaptor throughout the pressure range. The SDX® V also features an improved wear life / performance and effortless maintenance for the lowest cost of ownership.

SDX® V Assembly Description and Part Numbers			
Description	Part Number	Material	
(A) Body	W194990013	Stainless Steel	
(B) Orifice O-Ring	W155100164	Silicone	
	A313520163	Viton	
(C) Orifice Disc	W19581-XXX*	Tungsten Carbide	
(D) Swirl Chamber	See Swirl Chamber Chart		
(E) Retainer O-Ring	W155100180	Silicone	
	A313520189	Viton	
(F) Standard Retainer	W195490013	Stainless Steel	
	W198300003	Stainless Steel	
Crown Retainer	See Swirl Chamber Chart		
End Plate	W053660012	Tungsten Carbide	
(G) Body O-Ring	W155100222	Silicone	
	A313520221	Viton	
(H) Adaptor	BSPT Thread	NPT Thread	
	1/4 Adaptor	W195000010	W196350018
3/8 Adaptor	W195000028	W196350026	Stainless Steel
1/2 Adaptor	W195000036	W196350034	Stainless Steel
3/4 Adaptor	W195000044	W196350042	Stainless Steel
Removal Tool	W196440025	DurAl	
SDX® Adaptor	W19636	Stainless Steel	
SDX® II/III Adaptor	W19637	Stainless Steel	
SDX® V Seal Kit	(10 of each O-Ring)		
	W197690016	Viton	
	W197690024	Silicone	

\* Specify orifice size and swirl chamber suffix from capacity chart, on pages 14-15

**Please Note:** This chart is only a limited illustration of available sizes. Special materials are available on request for particular applications, please contact us for prices and delivery.

SDX® V Swirl Chamber Part Numbers				
Ref	Standard*	Flat Back*	Open*	Crown Retainer*
SA	W194720014	W198290014	W209710018	W211240012
SB	W194720022	W198290022	W209710026	W211240020
SC	W194720030	W198290030	W209710034	W211240038
SD	W194720048	W198290048	W209710042	W211240046
SE	W194720055	W198290055	W209710059	W211240053
SF	W194720063	W198290063	W209710067	W211240061
SG	W194720071	W198290071	W209710075	W211240079
SH	W194720089	W198290089	W209710083	W211240087
SI	W194720097	W198290097	W209710091	W211240095
SJ	W194720105	W198290105	W209710109	W211240103

\*Standard Swirl Chamber uses Standard Retainer W195490013 or Crown Retainer W209700001

\*Flat Back Swirl Chamber uses Cross Milled Retainer W198300003 or Crown Retainer W209700001

\*Open Swirl Chamber uses Crown Retainer (Various Sizes)

\*Crown Retainer Part Numbers to be used with Open Swirl Chamber

SDX® V Interface Adaptors			
Part Number	Ref	Size	
SDX® to SDX® V Interface Adaptor			
W19636	- 1	1/4" NPT	
W19636	- 2	3/8" NPT	
W19636	- 3	1/2" NPT	
W19636	- 4	3/4" NPT	
SDX® II & III to SDX® V Interface Adaptor			
W19637	- 1	1/4" NPT	
W19637	- 2	3/8" NPT	
W19637	- 3	1/2" NPT	
W19637	- 4	3/4" NPT	

Delavan® can offer a range of interface adaptors for the SDX® V nozzle. These can be used when converting from previous SDX® nozzles over to the new SDX® V nozzle. The interface adaptors are there to ensure that the same overall nozzle length of nozzle assembly is achieved.

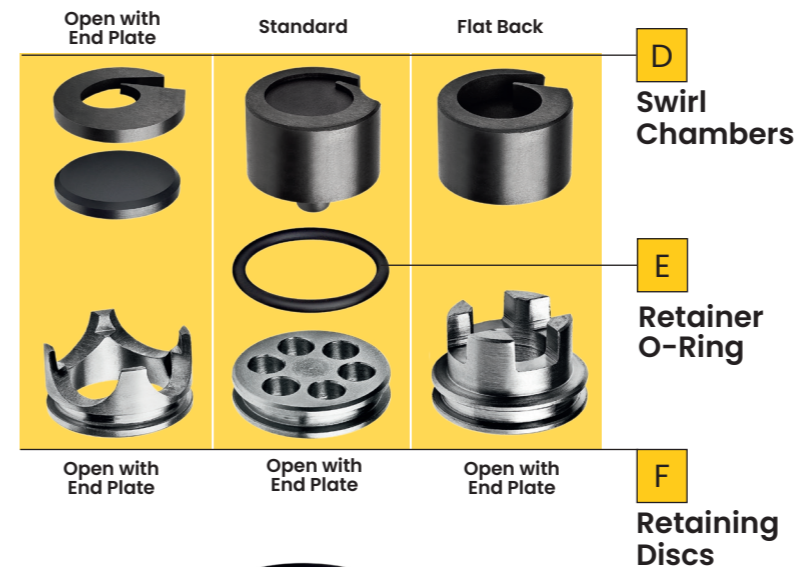
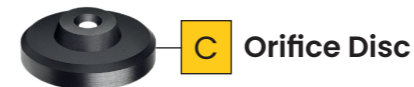
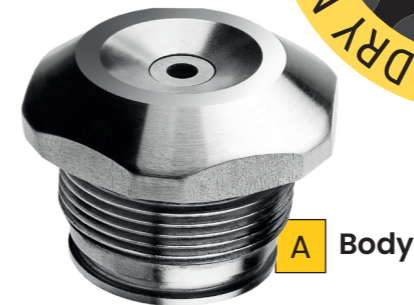
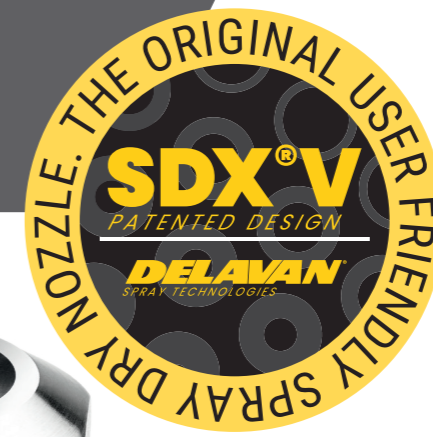

## Assembly Procedure:

1. Place Nozzle Body **(A)** thread side up on a flat surface
2. Insert the Orifice O-Ring **(B)** into the Nozzle Body **(A)**
3. Insert the Orifice Disc **(C)** in to the Nozzle Body **(A)** with the 'orifice nose' (the small diameter section of the orifice) inserted first so that the tapered inlet section can be seen
4. Place Swirl Chamber **(D)** on top of the Orifice Disc **(C)** with the 'swirl profile' located against the back face of the Orifice Disc **(C)**
5. Ensure that the Retainer O-Ring **(E)** is fitted onto the Retaining Disc **(F)**
6. Push the Retaining Disc **(F)** into the Nozzle Body **(A)** until unit is pressed flat against the back face of the Swirl Chamber **(D)** and Nozzle Body **(A)**
7. Place the Body O-Ring **(G)** into the body o-ring groove positioned above the threads on the outside of the Nozzle Body **(A)**
8. Pick up assembled unit and screw into Female Adaptor **(H)**, hand tighten

# SDX® Performance and Spray Quality



## The Atomizer

Installing the right atomizer is an essential step to ensuring spray drying success. The atomizer must fulfill several important functions:

1. It must disperse the feed material into small droplets, which should be well distributed within the dryer and mixed thoroughly with the hot gas.
2. The size of the droplets produced must be compatible with the required product particle size characteristics.
3. The droplets produced must not be so large that they are incompletely dried, nor so small that product recovery is difficult – small particles may also overheat and become scorched.
4. The atomizer must act as a metering device, controlling the flow rate at which the material is fed into the spray dryer.

## Centrifugal Pressure Nozzles

The SDX® represents Delavan's range of centrifugal spray drying nozzles. Energy for atomization is supplied solely by the feed liquid pressure with pressures up to 700 Bar. The SDX® range uses a single inlet

swirl chamber and can atomize liquids with viscosities up to several hundred centipoise. All the SDX® nozzles use orifice discs, thereby guaranteeing uniformity of performance across the range.

## Two-Fluid Nozzles

In two-fluid nozzles, gas (or steam) supplies most of the energy required to atomize the liquid. Liquid admitted under low pressure may be mixed either internally or externally with the gas. Although energy requirements for this atomizer are generally greater than

the spinning discs or pressure nozzles, the two-fluid nozzle can produce very fine atomization, particularly with viscous materials. It is often used in laboratory and small spray dryers.

## Liquid Properties

The properties of the feed stock are directly related to the finished particle size. Therefore density, viscosity, percentage solids, abrasive awareness, and any other characteristics all need to be considered. The liquid properties should be established at the temperature corresponding to the liquid in the nozzle. Feed stocks are often sprayed at elevated temperatures to decrease viscosity, thereby improving atomization.

The effect of each liquid property on droplet size is usually established by actual test. However, Delavan's field experience shows that these effects can be closely estimated from the following correction factors.

### Spray Quality and Particle Size

While durability is one of the foremost requirements of pressure nozzles, atomization quality and droplet size are just as critical. Droplet size affects not only dryer size and operating efficiency but also the characteristics of the final product. Particle size is critical with regard to bulk density, solubility, and customer acceptance. Distinguishing between droplet size and particle size is important, since the two are generally not identical, although the relationship between the two can often be determined by on-site trials. Particle size or droplet size is usually expressed in terms of a mean or average diameter as well as the range in size.

### Droplet Diameters

Delavan® uses the Sauter mean diameter, whose ratio of volume to surface area is equal to that of the aggregate spray, to measure the droplet diameter. Typically, a spray drying nozzle will produce droplets as small as 1-2 micron and as large as 400-500 micron. However, the majority will be within a range of 50-200 micron. The narrower the range of droplet size, the more suited it is to spray drying, with a 'mono-range' being the ultimate goal for most operators.

### Spray Angle

The spray angle in spray drying is usually in the 60° to 90° band. However, the spray angle measured near the orifice may not prevail further away, particularly at high pressures, when the angle becomes narrower within a short distance.

### Flow Variation

SDX® nozzles can also act as metering devices, controlling the distribution of feed into the chamber. Whether a single or multi-nozzle application, the flow rate must be precisely controlled to be compatible with the dryer design. Therefore, it is important to understand the properties of the feed material.

### Wear Resistance

The wear life of the internal parts (consumable parts) depends on their corrosion- and erosion-resistant characteristics. Corrosion occurs when the liquid feed and wear parts are chemically incompatible. Corrosion problems can be avoided if the chemical properties of the feed stock are known and the material of the consumable parts are designed to be compatible. Erosion results from the liquid feed's abrasive solids physically removing the material. Erosion can be combated using harder materials but never fully overcome.

## Effect of Liquid Viscosity

$$D \propto m^{0.25}$$

$$D \propto s^{0.33}$$

D = Mean Droplet Diameter (Micrometers)  
 m = Absolute Viscosity (Centipoise)  
 s = Surface Tension (Dynes/cm)

# SDX® Product Line

## SDX® V

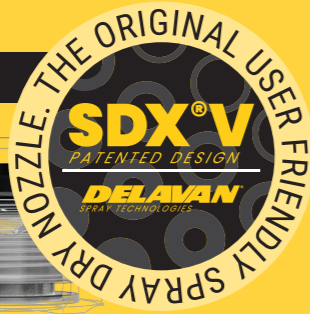

Our most user-friendly nozzle with eight part construction and lowest total cost of ownership.

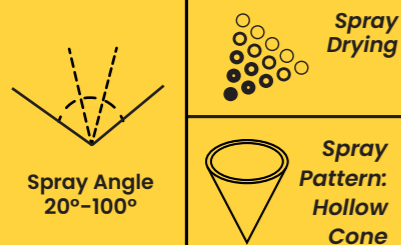

## SDX® III



Seven part nozzle featuring O-Rings for sealing so it can be hand tightened. Effortless scale-up to the larger SDX® V nozzle.

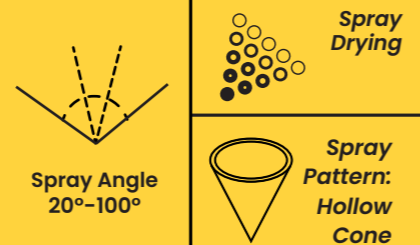

## SDX®



Classic eight part construction nozzle used for high pressure and high temperature applications.

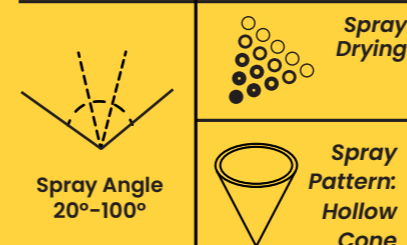

## COMPACT SDX®



Small size nozzle with a higher flow range.

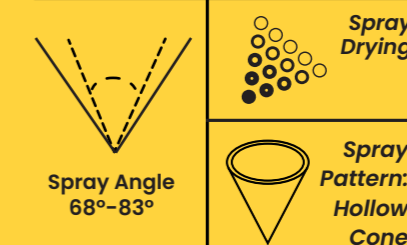

## MINI SDX®



Small, low-flow nozzle for lower capacity applications.

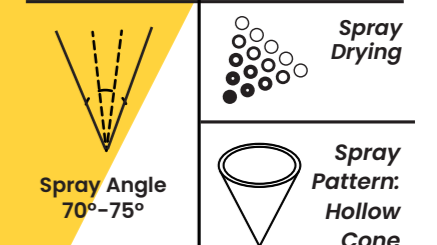

## Our SDX® Nozzles Promise High Performance and Rugged Durability.

With 13 sizes of swirl chamber and over 220 orifice sizes, the ability to fine tune the flow rate and spray angle is almost limitless. The SDX® offers flow rates from 6 – 1400 gph @ 1000 psi (69 bar) and carry a proven pressure rating to 10,000 psi (690 bar) without the need for expensive back up rings.

Delavan® is continually evaluating the critical design features of the various models of nozzle that comprise the SDX® range. This engineering work, combined with feedback from thousands of users around the world, generates opportunities to improve the performance of the product as well as lowering the cost of ownership and simplifying maintenance.

## Where We Lead, Others Follow!

The Delavan SDX® range of spray drying nozzles set the standard by which other nozzles are judged. We were the first to hold a patent on the revolutionary swirl chamber design with a single inlet, which minimizes plugging and maximizes particle uniformity. This design has improved dry product quality because the spiral configuration conforms to the natural path of liquid as it progresses toward the orifice.

**Additionally, Delavan® originally developed many more of the technologies that make the SDX® the standard in dry spraying, including:**

- The hand tighten assembly with the SDX® III
- The retaining feature with the SDX® and then simplified with the SDX® V
- The use of sealing surfaces into carbide components with the Compact SDX®

## SDX® V Spray Dry Nozzle Flow Rate Charts

Orifice sizes ranging from 0.016" – 0.250" in increments of 0.001" swirl chambers ranging from SA (0.76mm) to SM (16mm). The orifice and swirl chamber sizes below show an example of some possible combinations. With over 220 orifice sizes and 10 swirl chamber variants allows us to find a combination to suit your droplet size, flow rate, and spray angle requirements.

All spray angles are based on water at a pressure of 1000 psi (69 bar). The MINI SDX® has a nominal spray angle of 70° - 75° due to its unique cone faced orifice.

SDX® Nozzles Range Capacity Chart															
Metering Sets (Swirl Chamber/Office)					Spray Angle	Flow Rate in Liters/HR at BAR G					Flow Rate in USGPH at PSIG				
Swirl Chamber Type				Orifice	(1000 PSIG)	Flow Rate in Liters/HR at BAR G					Flow Rate in USGPH at PSIG				
Mini SDX®	Compact SDX®	SDX® SDX® III	SDX® V	Orifice Dia (in)	Measured with Water	69	138	207	276	345	1000	2000	3000	4000	5000
SW4	-	-	-	0.016	70°-75°	21	30	37	42	47	6	8	10	11	12
SW4	-	-	-	0.018	70°-75°	24	34	42	48	54	6	9	11	13	14
SW4	-	-	-	0.020	70°-75°	26	36	45	51	57	7	10	12	14	15
SW4	-	-	-	0.022	70°-75°	28	40	49	57	64	8	11	13	15	17
SW4	-	-	-	0.024	70°-75°	33	46	56	65	73	9	12	15	17	19
-	SAC	SA	SAV	0.025	68°	51	72	89	102	114	13	19	23	27	30
SW1	-	-	-	0.027	70°-75°	55	78	95	110	123	14	20	25	29	32
-	SAC	SA	SAV	0.028	71°	57	80	98	114	127	15	21	26	30	33
SW1	-	-	-	0.030	70°-75°	62	88	108	125	140	16	23	29	33	37
-	SAC	SA	SAV	0.031	74°	62	88	108	125	140	16	23	29	33	37
SW1	-	-	-	0.033	70°-75°	66	93	114	132	147	17	25	30	35	39
-	SAC	SA	SAV	0.034	77°	68	96	118	136	152	18	25	31	36	40
SW1	-	-	-	0.036	70°-75°	71	101	123	142	159	19	27	33	38	42
-	SAC	SA	SAV	0.037	79°	76	107	131	151	169	20	28	35	40	45
SW2	-	-	-	0.038	70°-75°	100	142	177	201	224	26	37	47	53	59
-	SBC	SB	SBV	0.040	76°	95	134	164	189	212	25	35	43	50	56
SW2	-	-	-	0.042	70°-75°	114	160	197	114	254	30	42	52	30	67
-	SBC	SB	SBV	0.043	78°	104	147	180	208	233	27	39	48	55	61
SW2	-	-	-	0.044	70°-75°	119	168	207	238	266	31	44	55	63	70
-	SBC	SB	SBV	0.046	80°	114	160	197	227	254	30	42	52	60	67
SW2	-	-	-	0.048	70°-75°	132	187	228	265	296	35	49	60	70	78
-	SBC	SB	SBV	0.049	81°	121	171	210	242	271	32	45	55	64	72
SW2	-	-	-	0.050	70°-75°	140	198	243	280	313	37	52	64	74	83
-	SBC	SB	SBV	0.052	82°	129	182	223	257	288	34	48.1	59	68	76
SW3	-	-	-	0.054	70°-75°	191	270	331	382	389	50	71	87	101	103
-	SCC	SC	SCV	0.055	78°	170	241	295	341	382	45	64	78	90	101
SW3	-	-	-	0.056	70°-75°	202	286	351	405	453	53	76	93	107	120
-	SCC	SC	SCV	0.058	79°	182	257	314	363	405	48	68	83	96	107
SW3	-	-	-	0.060	70°-75°	219	310	380	439	491	58	82	100	116	130
-	SCC	SC	SCV	0.061	80°	193	273	334	386	431	51	72	88	102	114
SW3	-	-	-	0.062	70°-75°	231	327	400	462	516	61	86	106	122	136
-	SCC	SC	SCV	0.064	81°	202	286	351	405	454	53	76	93	107	120

SDX® Nozzles Range Capacity Chart															
Metering Sets (Swirl Chamber/Office)					Spray Angle	Flow Rate in Liters/HR at BAR G					Flow Rate in USGPH at PSIG				
Swirl Chamber Type				Orifice	(1000 PSIG)	Flow Rate in Liters/HR at BAR G					Flow Rate in USGPH at PSIG				
Mini SDX®	Compact SDX®	SDX® SDX® III	SDX® V	Orifice Dia (in)	Measured with Water	69	138	207	276	345	1000	2000	3000	4000	5000
-	SCC	SC	SCV	0.067	82°	212	300	367	424	473	56	79	97	112	125
-	SCC	SC	SCV	0.070	83°	225	318	390	450	503	59	84	103	119	133
-	SDC	SD	SDV	0.073	78°	291	413	503	583	651	77	109	133	154	172
-	SDC	SD	SDV	0.076	79°	310	439	538	621	693	82	116	142	164	183
-	SDC	SD	SDV	0.079	80°	325	462	564	651	727	86	122	149	172	192
-	SDC	SD	SDV	0.082	81°	334	477	583	674	753	89	126	154	178	199
-	SDC	SD	SDV	0.085	82°	348	492	602	696	780	92	130	159	184	206
-	SDC	SD	SDV	0.088	83°	364	515	628	727	814	96	136	166	192	215
-	-	SE	SEV	0.091	78°	469	662	814	939	1048	124	175	215	248	277
-	-	SE	SEV	0.094	79°	484	685	840	969	1082	128	181	222	256	286
-	-	SE	SEV	0.097	80°	500	708	867	999	1117	132	187	229	264	295
-	-	SE	SEV	0.100	80°	515	727	893	1029	1151	136	192	236	272	304
-	-	SE	SEV	0.103	81°	530	749	920	1060	1185	140	198	243	280	313
-	-	SF	SFV	0.106	76°	723	1022	1253	1446	1616	191	270	331	382	427
-	-	SF	SFV	0.109	76°	749	1060	1298	1499	1677	198	280	343	396	443
-	-	SF	SFV	0.112	77°	769	1086	1332	1537	1718	203	287	352	406	454
-	-	SF	SFV	0.115	77°	787	1113	1363	1575	1760	208	294	360	416	465
-	-	SF	SFV	0.118	78°	814	1151	1408	1628	1821	215	304	372	430	481
-	-	SG	SGV	0.121	73°	1003	1419	1737	2006	2244	265	375	459	530	593
-	-	SG	SGV	0.124	73°	1026	1450	1775	2051	2294	271	383	469	542	606
-	-	SG	SGV	0.127	74°	1052	1487	1824	2104	2354	278	393	482	556	622
-	-	SG	SGV	0.130	75°	1079	1525	1870	2157	2411	285	403	494	570	637
-	-	SG	SGV	0.133	75°	1105	1563	1915	2210	2472	292	413	506	584	653
-	-	SH	SHV	0.136	70°	1567	2214	2714	3134	3505	414	585	717	828	926
-	-	SH	SHV	0.14	71°	1628	2301	2820	3255	3641	430	608	745	860	962
-	-	SH	SHV	0.145	72°	1703	2407	2948	3406	3808	450	636	779	900	1006
-	-	SH	SHV	0.15	73°	1760	2490	3047	3520	3936	465	658	805	930	1040
-	-	SH	SHV	0.155	74°	1817	2570	3145	3634	4061	480	679	831	960	1073
-	-	SI	SIV	0.16	70°	2044	2892	3539	4088	4568	540	764	935	1080	1207
-	-	SI	SIV	0.165	71°	2195	3104	3804	4391	4910	580	820	1005	1160	1297
-	-	SI	SIV	0.17	72°	2347	3319	4065	4693	5246	620	877	1074	1240	1386
-	-	SI	SIV	0.175	73°	2460	3478	4262	4920	5500	650	919	1126	1300	1453
-	-	SI	SIV	0.18	74°	2555	3615	4425	5110	5712	675	955	1169	1350	1509
-	-	SI	SIV	0.185	75°	2649	3747	4587	5299	5923	700	990	1212	1400	1565
-	-	SJ	SJV	0.19	71°	3293	4656	5704	6586	7362	870	1230	1507	1740	1945
-	-	SJ	SJV	0.195	72°	3369	4765	5836	6737	7532	890	1259	1542	1780	1990
-	-	SJ	SJV	0.20	73°	3463	4898	5999	6927	7744	915	1294	1585	1830	2046
-	-	SJ	SJV	0.205	74°	3634	5136	6294	7267	8126	960	1357	1663	1920	2147
-	-	SJ	SJV	0.21	75°	3785	5352	6556	7570	8463	1000	1414	1732	2000	2236

The orifice and swirl chamber charts show an example of some possible combinations. For a nozzle combination specific to your flow rate, droplet size, and spray angle, please contact us.



# SDX® V Accessories

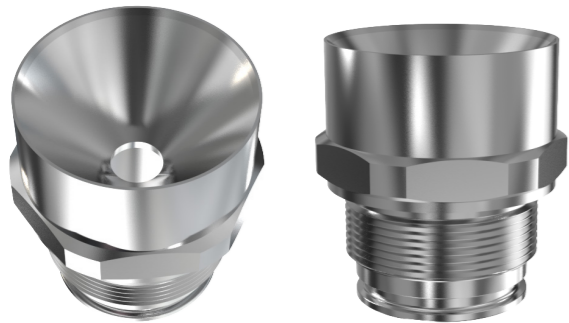

## Cone Faced Body

These are designed to prevent build up on the front face of the nozzle body. Available in angles to suit individual applications.

Cone Faced Body Part Numbers			
Nozzle	70°	80°	90°
SDX®	A203190010	A203190028	A203190036
SDX® III	W118820015	W118820023	W118820031
SDX® V	W196000019	W196000027	W196000035

## Check Valves

There are several versions of non drip check valves available for the SDX® range of nozzles. Please contact the factory for further information.



## Butt Weld Adaptor

We offer the butt weld adaptor in a range of standard pipe sizes, configurations, and lengths, with custom designs available upon request. Ensure that adaptor welds are carried out to the appropriate safety approvals and standards.

## Seal Kits

We supply seal kits for the SDX® V nozzle in various materials. Each kit comprises of 10 of each seal. Delavan® recommends that seals are changed after each run.

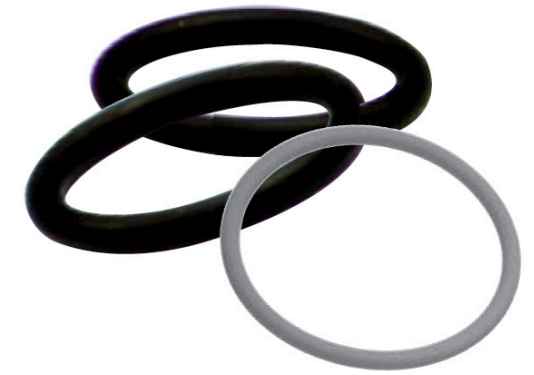

## O-Ring Temperature Aptitude Graph (°C)

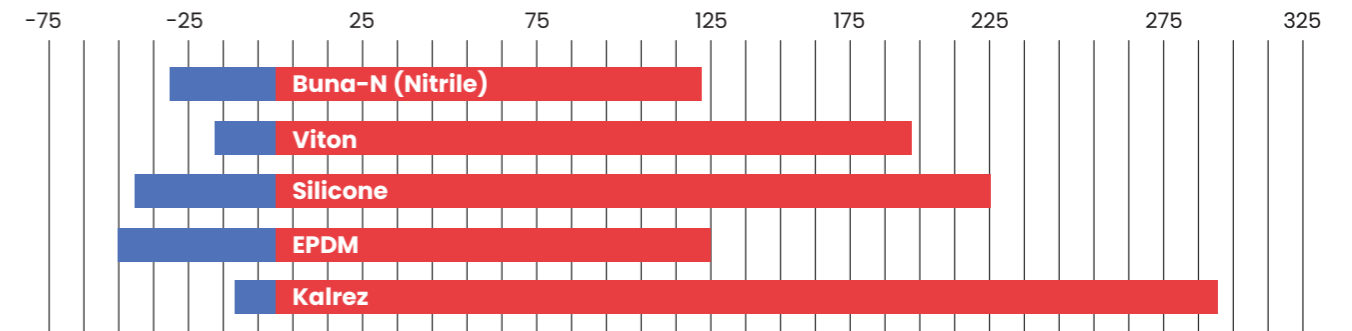

The O-ring, otherwise known as Toroidal Seal, is an exceptionally versatile sealing device. Delavan-supplied O-rings are of the highest quality currently available on the market and are specified specifically for our nozzle components. This data sheet offers Delavan O-ring consumers a range of performance and compatibility data from our standard supply materials. We recognize that not all applications are suitable for these standard, readily available materials and offer alternatives to suit individual applications on request. We are also able to offer FDA (Food and Drug Association) approved materials accompanied by a certificate.

## SDX® Carbide Reference Guide

Delavan® Reference	Carbide Description	Abrasion	SRS Star Rating Corrosion	Erosion
Standard Grade	General Purpose Tungsten Carbide Used in all of Delavan's SDX® products and suitable for most applications	★★★	★★★	★★★
Standard Plus Grade	General Purpose Tungsten Carbide Improved resistance for use with High Pressure applications	★★★★★	★★★★★	★★★★★
Superior Grade	Specialty Tungsten Carbide Best suited for pure Chemical Resistance with Caustic or Acid materials	★★	★★★★★	★★★★★

Delavan's Star Rating System (SRS) outlines three primary properties of wear on our carbide products; abrasion, corrosion and erosion. Scale = Lowest Rating (★) to Highest Rating (★★★★★). The SDX® family of products comes with carbide internal components made from our standard grade of carbide which is noted by our part numbers. Please contact Delavan® for questions on our complete line of material selections. Caution: These ratings are subject to each application and should be used as a general guide.

# Maintenance Considerations

The Delavan SDX® nozzle range has been specifically designed for high pressure applications with the SDX® III configuration being in service throughout the world for over 40 years. Each component throughout the SDX® range is precision machined to tested and proven dimensions with close tolerances to suit the exacting requirements demanded by the process.

In order to ensure that the nozzles continue to operate effectively, it is vital that each component is handled carefully, ensuring that there is no damage to the components. This is particularly important with the sealing surface areas and the threads. Any slight damage to a sealing face or surface, or to a thread profile, can potentially cause an issue. If there is any doubt about the condition of a component, Delavan® would suggest that the item is replaced.

The Delavan SDX® range of nozzles has been operating successfully and safely throughout the world for over 60 years. In developing the SDX® range, independent high pressure cycling and proof pressure testing was commissioned in order to ensure that we can support the ever increasing demands of our customers.



Incorrect orifice and swirl chamber material selection, resulting in premature wear. For advice on material and compatibility contact Delavan®.



Damage to threads on SDX® III Nozzle.

# Training

The Delavan SDX® range of nozzles are fully supported in the field through organized training sessions and backed by decades of technical experience in spray drying. Delavan® offers a maintenance and training program for operators and OEMs to ensure that you have all of the tools necessary for trouble free operation of your spray nozzles.

### Some of the topics covered are:

- Maintenance
- Assembly / disassembly
- Inspection of carbide components, the effects of wear, and what to look out for
- Good practice guide
- Cleaning / CIP

# Ordering

Ordering guides are available to suit specific requirements, contact Delavan® for more information.

**DELAVAN**  
SPRAY TECHNOLOGIES

Gorseley Lane  
Widnes  
Cheshire  
WAB 0RJ  
Tel - 0044 (0) 151 424 6821  
Email - sales@Delavan.co.uk

## SDX® V Part Selection and Order Guide

E) RET DISC O RING  
A313520189



B) SDX V ORIFICE O RING  
A313520163



A) SDX V BODY  
W194990013



H) Nozzle Adaptor SDX 5 1/4"  
Sch.40 B/W SS 316L W218780033  
(WELDED TO LANCE)



F) SDX V RET DISC  
W198300003

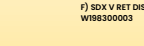

SWIRL CHAMBER VARIATIONS	
SDX V SWIRL CHAMBER SD TC	W198290048
SDX V SWIRL CHAMBER SE TC	W198290055
SDX V SWIRL CHAMBER SF TC	W198290063
SDX V SWIRL CHAMBER SG TC	W198290071

ORIFICE DISC VARIATIONS	
SDX V ORIFICE DISC 076 TC	W195810764
SDX V ORIFICE DISC 080 TC	W195810806
SDX V ORIFICE DISC 100 TC	W195811002

**DELAVAN**  
SPRAY TECHNOLOGIES

Gorseley Lane  
Widnes  
Cheshire  
WAB 0RJ  
Tel - 0044 (0) 151 424 6821  
Email - sales@Delavan.co.uk

## SDX® V Nozzle Assembly Instructions

E) RET DISC O RING  
A313520189



B) SDX V ORIFICE O RING  
A313520163



A) SDX V BODY  
W194990013



H) Nozzle Adaptor SDX 5 1/4"  
Sch.40 B/W SS 316L W218780033  
(WELDED TO LANCE)



F) SDX V RET DISC  
W198300003



- 1) Place **Nozzle Body (A)** thread side up on a flat surface
- 2) Insert the **Orifice O Ring (B)** into the **Nozzle Body (A)**
- 3) Insert the **Orifice Disc (C)** into the **Nozzle Body (A)** with the 'orifice nose' (smallest diameter inserted first into the nozzle body, locating at the front)
- 4) Place **Swirl Chamber (D)** on top of the **Orifice Disc (C)** with the swirl side contacting the **Orifice Disc (C)**
- 5) Ensure that the **Retainer O Ring (E)** is fitted onto the **Retaining Disc (F)**
- 6) Push the **Retaining Disc (F)** into the **Nozzle Body (A)** until it is pressed flat against the back of the swirl chamber
- 7) Place the **Body O Ring (G)** into the body o ring groove positioned above the threads on the outside of the **Nozzle Body (A)**
- 8) Ensure that the complete assembly doesn't rattle
- 9) Pick up assembled unit and screw into the **Adaptor (H)** and tighten by hand

ENSURE THAT 'O' RINGS ARE CHANGED EVERY TIME MAINTENANCE IS CARRIED OUT USING GENUINE DELAVAN COMPONENTS

10/06/2014 - A NIXON

# Understanding the "Custom" Aspect of Each Application is of Critical Importance to Spray Drying.

Almost every dryer presents a unique situation and that is why Delavan® uses computer analysis programs to produce information on spray angles and flow rates before installing any nozzles into the spray dryer, saving valuable time and money. Contact our Helpline or your local distributor for further information.

Tel: +44 (0)151 424 6821 or inside USA Toll Free: 1-877-GO DELAVAN  
E-mail: sales@delavan.com

Delavan®, part of R.W. Beckett, is a world leader in the design and manufacture of high quality spray nozzles and fluid handling systems. Since 1935, we have grown to be one of the leading spray nozzle manufacturers. Operating from dedicated manufacturing facilities, Delavan® now supplies more than 30,000 different components to thousands of customers in virtually every manufacturing and processing industry. Our success has been driven by our outstanding service, our manufacturing flexibility, and our technical application expertise to ensure our customers obtain the maximum benefit from the solutions they choose.

Precision Tested.  
People Trusted.

**DELAVAN**<sup>®</sup>  
SPRAY TECHNOLOGIES

For more information on our products and help connecting with a distributor near you, visit **delavan.com** or contact us at:

Phone: **+44 (0)151 424 6821**

Fax: **+44 (0)151 495 1043**

Inside USA Toll Free:

Phone: **1-877-GO DELAVAN**

Fax: **1-877-DELAFA**X

General Inquiries: **sales@delavan.co.uk**



**FM 523589**

**DELAVAN**  
A Beckett Company